

LG-T1921RGBA-TD-AL

DATA SHEET

SPEC. NO. : SZ22101501
DATE : 2022/10/15
REV. : A/0

Approved By:

Checked By:

Prepared By:



LG-T1921RGBA-TD-AL

TOP Full-color LED

Catalogue

Electrical Characteristics.....3

Typical Characteri56 TDcteri56 TDccteri5682 Tc 0 Tw 9 0-04 1 i 11.683e.449 36.023J 0.0013 Tc 10.52.731 1 T1

362(T) 9-5l Ch)8(aracterisReliability)17ter90 604 0- Items and Conditions168 29.36 TD[(...)]TJ 0.0013 Tc 10.568 6(.co)9730 Tm

Typical Characteristics Curves

Volt Ampere Characteristics

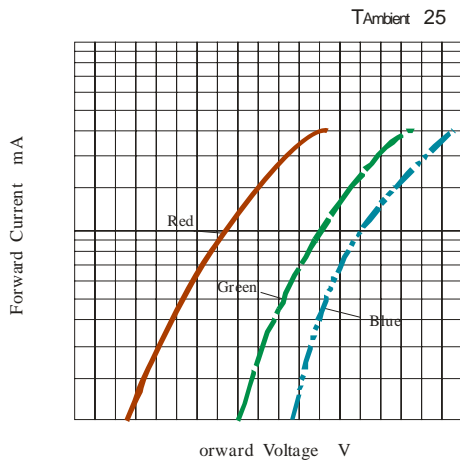

Relative Luminous Intensity VS Forward Current

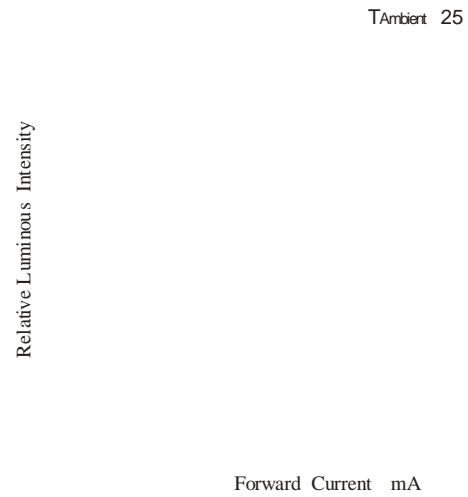

Forward Current Derating Curve

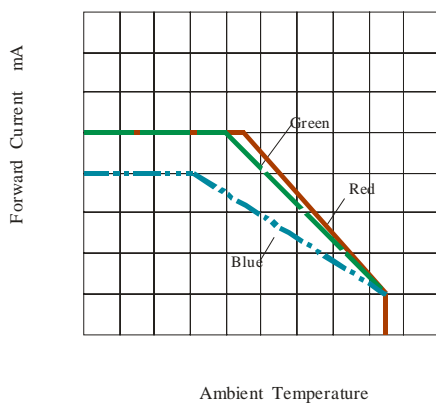

Relative Spectral Distribution

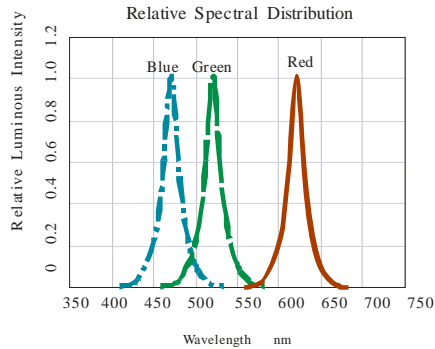

Typical Spatial Distribution

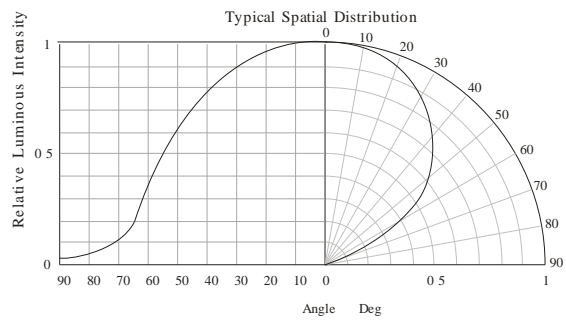

Reliability Test Items And Conditions

| 实验项目 Test Items | 参考标准 Reference | 实验条件 Test Conditions | 时间 Time | 样品数 Quantit | 判据 Crite |
|--|--------------------------|---|-------------------|----------------|-------------|
| Thermal Shock | MIL-STD-202G | -40 (30min)←→100 (30min) | 300 300 cycles | 22 | 0/22 |
| Temperature And Humidity Cyclic | JEITA ED-4701 200 203 | -10 ———+65 0%-90%RH 24hrs./1cycle | 10 10 cycles | 22 | 0/22 |
| High Temperature Storage | JEITA ED-4701 200 201 | Ta=100 | 1000h | 22 | 0/22 |
| Low Temperature Storage | JEITA ED-4701 200 202 | Ta=-40 | 1000h | 22 | 0/22 |
| High Temperature High Humidity Storage | JEITA ED-4701 100 103 | Ta=60 RH=90% | 1000h | 22 | 0/22 |
| Life Test | JESD22-A108D | Ta=25 IF _R =15mA,IF _G =8mA,IF _B =5mA | 1000h | 22 | 0/22 |
| High Temperature Life Test | JESD22-A108D | Ta=85 IF _R =15mA,IF _G =8mA,IF _B =5mA | 1000h | 22 | 0/22 |
| Low Temperature Life Test | JESD22-A108D | Ta=-40 IF _R =15mA,IF _G =8mA,IF _B =5mA | 1000h | 22 | 0/22 |
| Resistance to Soldering Heat | GB/T 4937, .2.2&2.3 | Tsol*=260 10sec. | 2 2 times | 22 | 0/22 |

Criteria For Judging Damage

| 测试项目 Test Items | 符号 Symbol | 测试条件 Test Conditions | 判定标准 Criteria For Judging Damage |
|------------------------------|----------------|----------------------------------|---|
| Forward Voltage | V _F | I _F = I _{FT} | ±10% Initial Data±10% |
| Reverse Current | I _R | V _R = 5V | I _R 10μA |
| Luminous Intensity | I _V | I _F = I _{FT} | I _V 30% I _V 50% Average I _V degradation≤30%; Single LED I _V degradation≤50% |
| Resistance to Soldering Heat | | | No dead light exists. |

* Tsol- I_{FT} * Note: Tsol-Temperature of tin liquid I_{FT} Typical current.

Product design and operational recommendation

1 mm

Product design Unit: mm

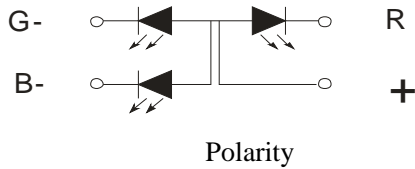
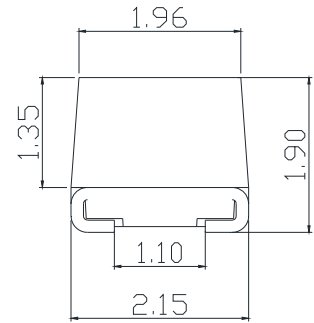
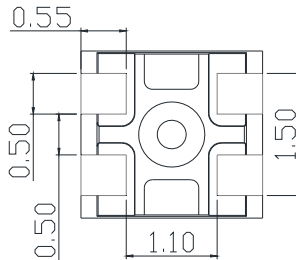
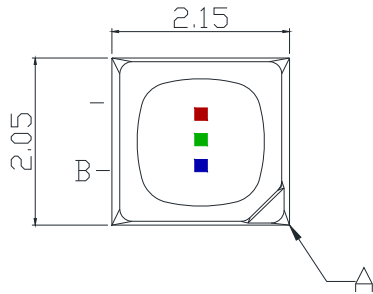

Note

A

A Nick Mark

X.X 0.1 mm X.XX 0.05mm

Tolerances X.X 0.1 mm X.XX 0.05mm

2 mm

Recommended soldering pad (Unit: mm)

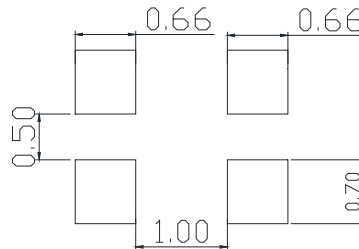

3 0.75mm

Recommendation for glue filling: filling height must be higher than or equal to 0.75mm

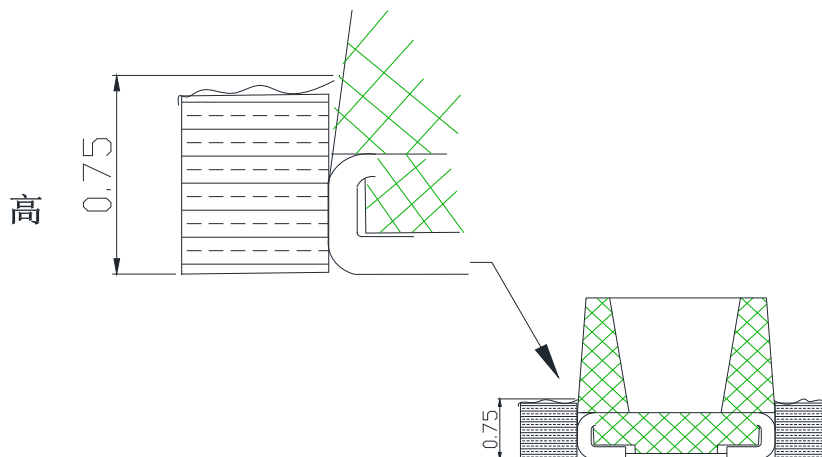

1

Packaging (1)

◇ Carrier Tape

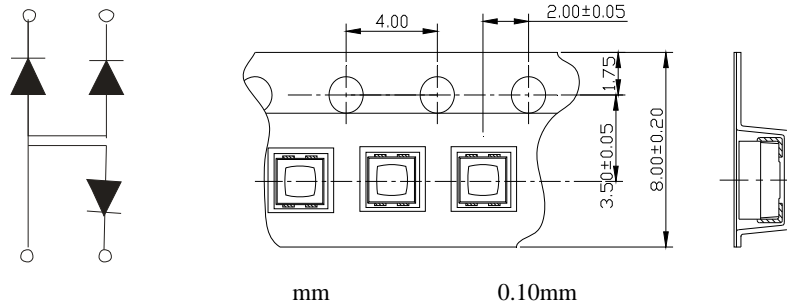

All dimensions in mm, tolerances unless mentioned is 0.10 mm.

◇ Details Of Carrier Tape

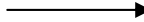
Progressive Direction 

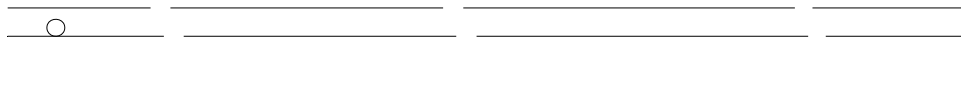

◇ Reel Dimension

Progressive Direction 

Label

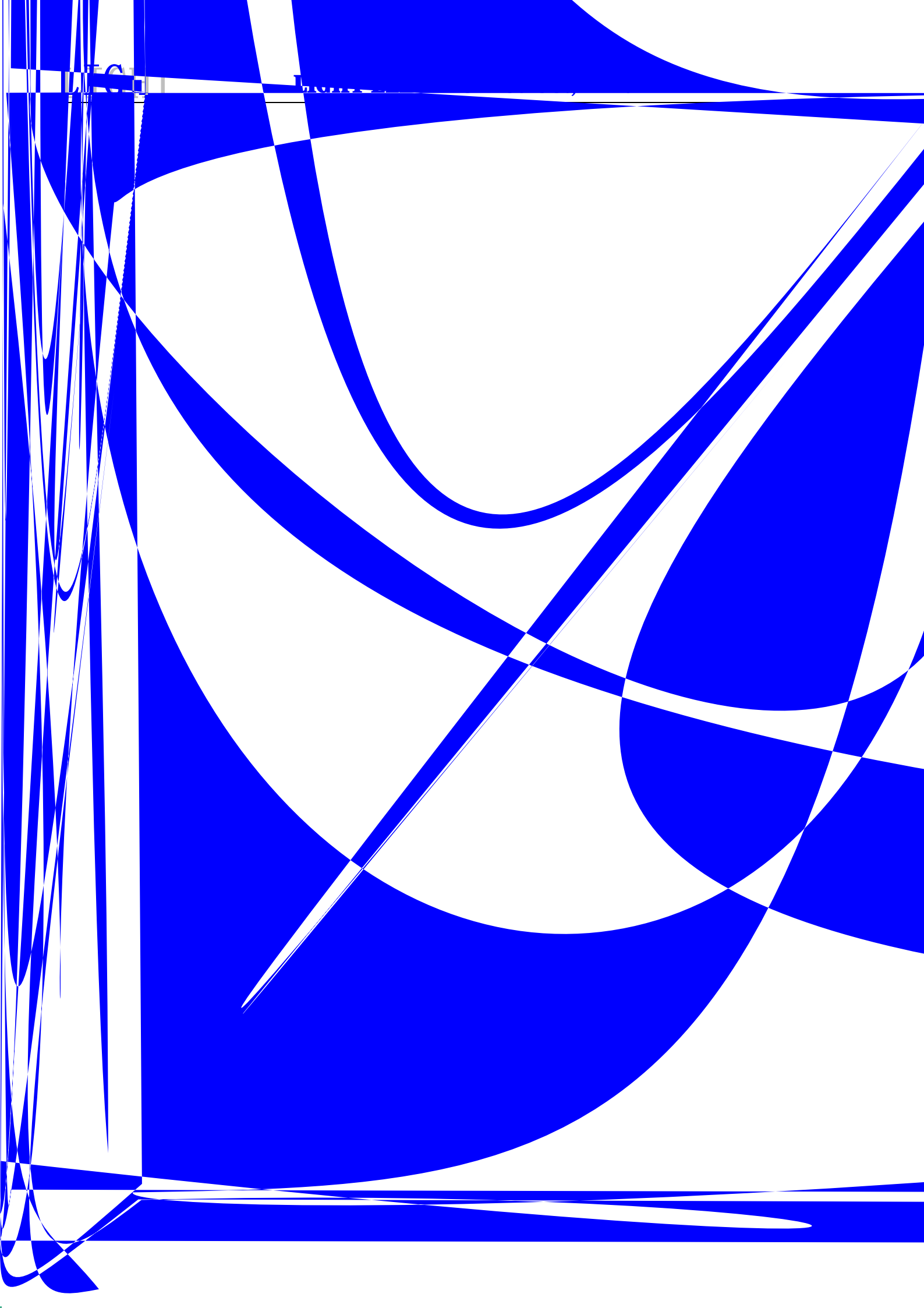

LLIGHT

LIGHT ELECTRONICS CO., LTD.

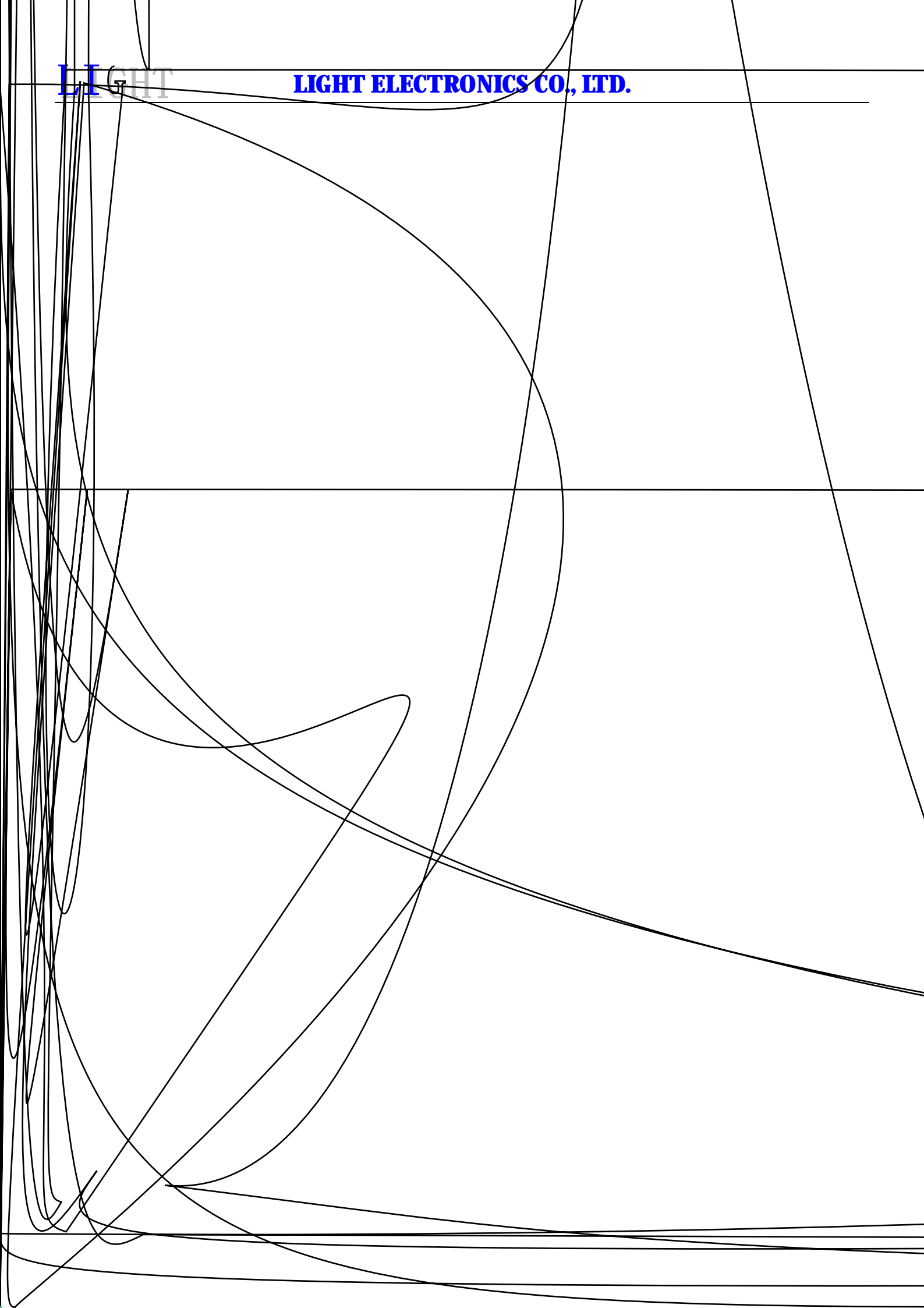

2

Guideline for Soldering (2)

Reflow soldering should not be done more than one time.

LED

Stress on the LEDs should be avoided during heating in the reflow soldering process.

LIGHT

LIGHT

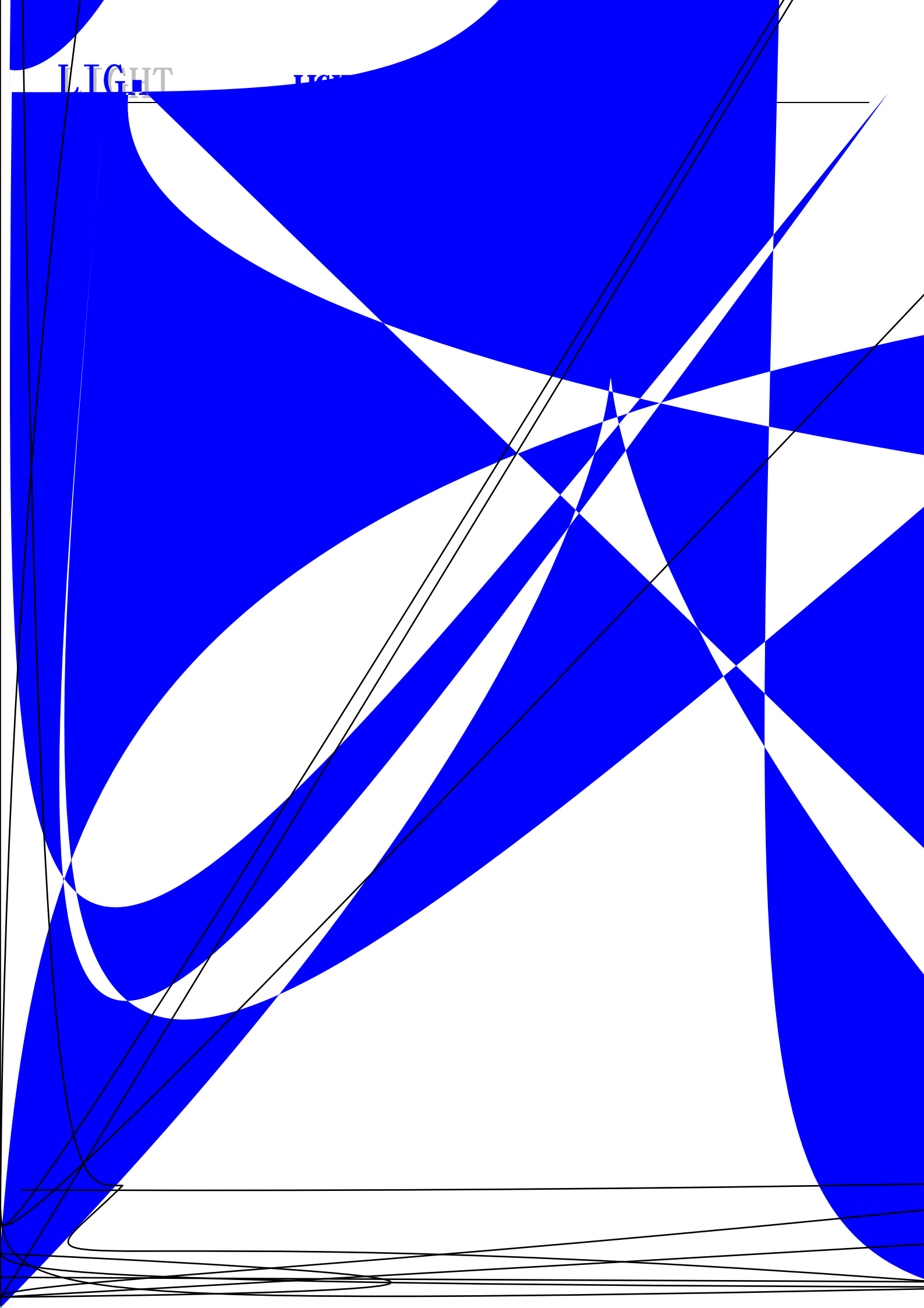

(2)

Precautions (2)

3.

Design Consideration

- LED

In designing a circuit, the current through each LED must not exceed the absolute maximum rating specified for each LED. In the meanwhile, resistors for protection should be applied, otherwise slight voltage shift will cause big current change which will probably lead to damage.

- A LED B LED
LED V_F LED

It is recommended to use Circuit A which regulates the current flowing through each LED rather than Circuit B. When driving LEDs with a constant voltage in Circuit B, the current through the LEDs may vary due to the variation in Forward Voltage (V_F) of the LEDs. In the worst case, some LED may be subjected to stress in the excess of the Absolute Maximum Rating.

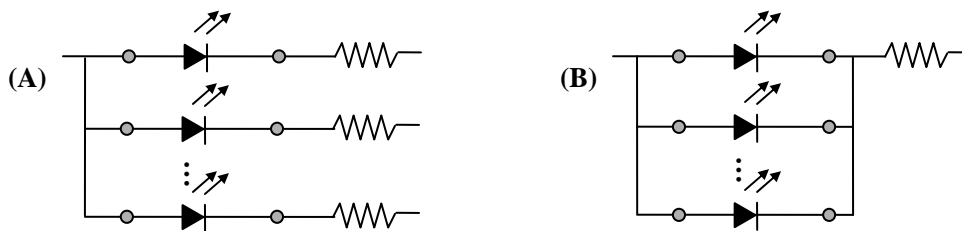

- LED LED

Thermal Design is paramount importance because heat generation may result in the Characteristics decline, such as brightness decrease, Color change and so on. Please consider the heat dissipation when making the system design.

4.

Reverse voltage protection

- LED LED
LED LED
LED 5V

In general, the reverse current of LED is very small, which won't affect the normal use of components. But when it is often suffered the reverse voltage which exceeds the limit of the component then it will be damaged.

